

## STELLAR BLAST 630 T4 1,5kW (509124050)

### GENERAL DATA



#### UP-BLAST TRANSMISSION VERTICAL DISCHARGE ROOF FAN MADE OF ALUMINUM

##### CONSTRUCTIVE FEATURES

- Up-Blast exhaust fan made entirely of aluminum that guarantees excellent corrosion resistance and minimum weight.
- Oversized Belt & Pulley Transmission (150% of the installed power). Oil and Static resistant belts.
- Bearings 100% factory tested and designed specifically for air movement applications with an L10 rating of 50,000 hours.
- Anti-vibration blocks reduce motion and noise transfer between transmission system and fan housing.
- High-performance aluminum built backward inclined impeller with self-cleaning system to minimize noise and vibrations.
- Q6.3 grade, statically and dynamically balanced fan for long life and quiet operation.
- Specially designed housing for rain protection. Protective grille to prevent entry of objects.
- Drain tube for easy removal of fluids (water and grease).
- Coated motor cable to prevent overheating and ensure long motor life.
- Standardized squirrel cage asynchronous motor with IP-54 protection and class F insulation. Standard voltages 230V 50Hz single-phase and three-phase motors.
- Inox bucket for grease collection, FAT TRAP, available for installation after the drain pipe (as accessori)

##### APPLICATIONS

Designed for deck or roof mounting, vertical discharge, indicated for:

- Professional kitchens.
- Smoke extraction.
- Cinemas.
- Air renewal in all types of buildings and industries.
- Maximum continuous working temperature: 150°C(fluid).
- Maximum ambient temperature: 50°C.

## PERFORMANCE CURVE

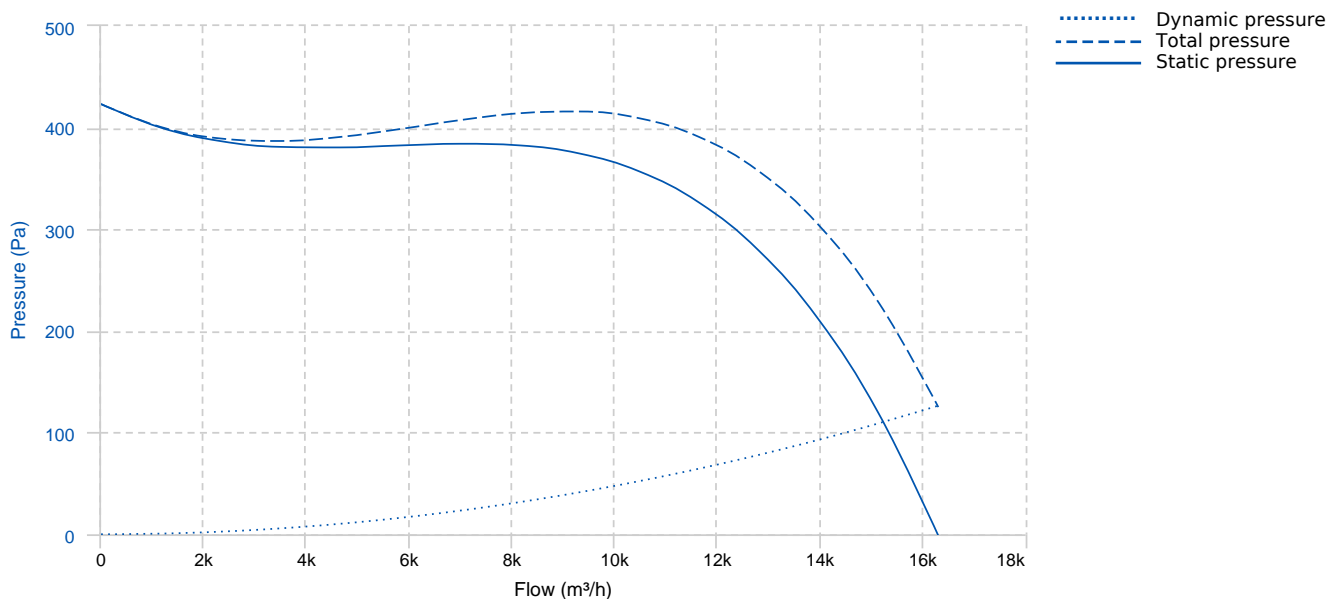

## TECHNICAL DATA

### Fan

RPM	1460	Approx. weight	114 kg	Max. Flow	16300 m³/h
-----	------	----------------	--------	-----------	------------

### Motor

Power	1.5 kW	RPM	1460rpm	I max. (230V)	6,6 A	Size	90L
Approx. weight	14 kg	Efficiency (%)	85,3 %	FP	0,77		

## DIMENSIONS

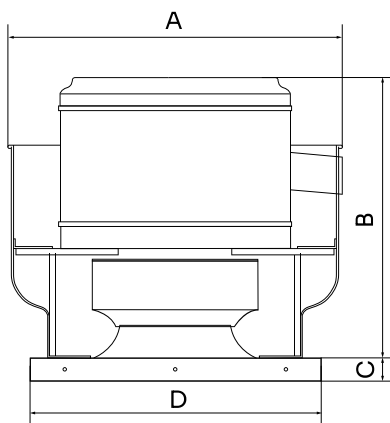

### Dimensions (mm)

A	1130	B	822	C	50.8	D	838
---	------	---	-----	---	------	---	-----

## WIRING DIAGRAM

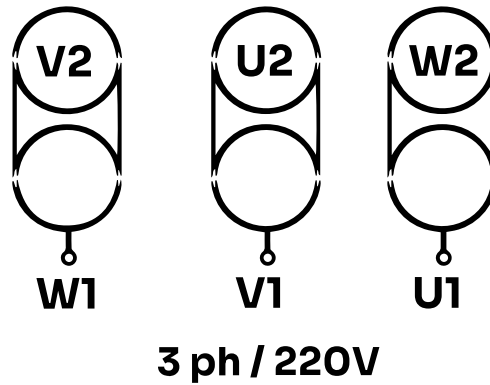

## ACCESSORIES



**SAFETY SWITCH**  
**INT 25 3P A**  
**REF: INT253PA**



**FREQUENCY SPEED CONTROLLER**  
**SFC 230 I 7A \***  
**REF: SFC230I007**



**STAINLESS STEEL GREASE BOX FOR**  
**RESTAURANT EXHAUST FAN**  
**FAT TRAP**  
**REF: 509129000**

## SPARE PARTS

	Code	Model	Qty
1	509124000SP01	MOTOR STELLAR BLAST 630 (B3)	x1
1	731090701	BELT SPAX 907	x2
1	732111802	PULLEY SPA118-2 ( 1610 )	x1
1	733161024	TAPER 1610D24	x1